

## FONTANA ATLANTA COMMERCIAL AUTOMATIC SENSOR FAUCET BRUSHED NICKEL SPECS

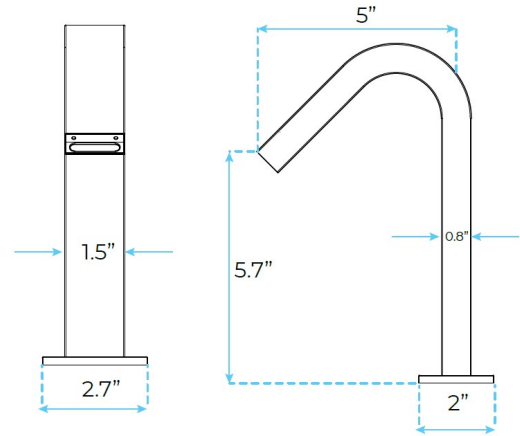

### **SPECS :**

Power: DC:6V(4AA alkaline battery)

AC:220V-240V; 50/60HZ

Water pressure: 0.05~0.86 MPa

Detection Zone: Automatic adjustment

Motor valve lifespan: up to 500000 flushes

Battery lifespan: 100000 cycles

Static Power Consumption: 0.36mw

Working Power consumption: 0.5mw

Senser Duration: Less than 0.5s

Shut-off Delay: 0.5~1 s

Dia.of inlet / outlet pipe: G1/2"

Flux:  $\geq 0.07L/S$

Temperature: 0.1-50°C

Flow Rate: No more than 2.0L/min at 0.3 MPa.

