

## AUTOMATIC DECK MOUNT SOAP DISPENSER SPECIFICATIONS



Spout: Brass

Power: 4 (D) Batteries / AC Adapter Optional

Soap Pump: 6 Volt Noise-Free PERISTALTIC Pump System

Sensor type: Active Infrared, Self-Adjusting

Working Soap: Standard liquid Soap. NO Grit (industrial) Soap

Soap Amount Per Use: 0.5ML to 1.5ML

Size

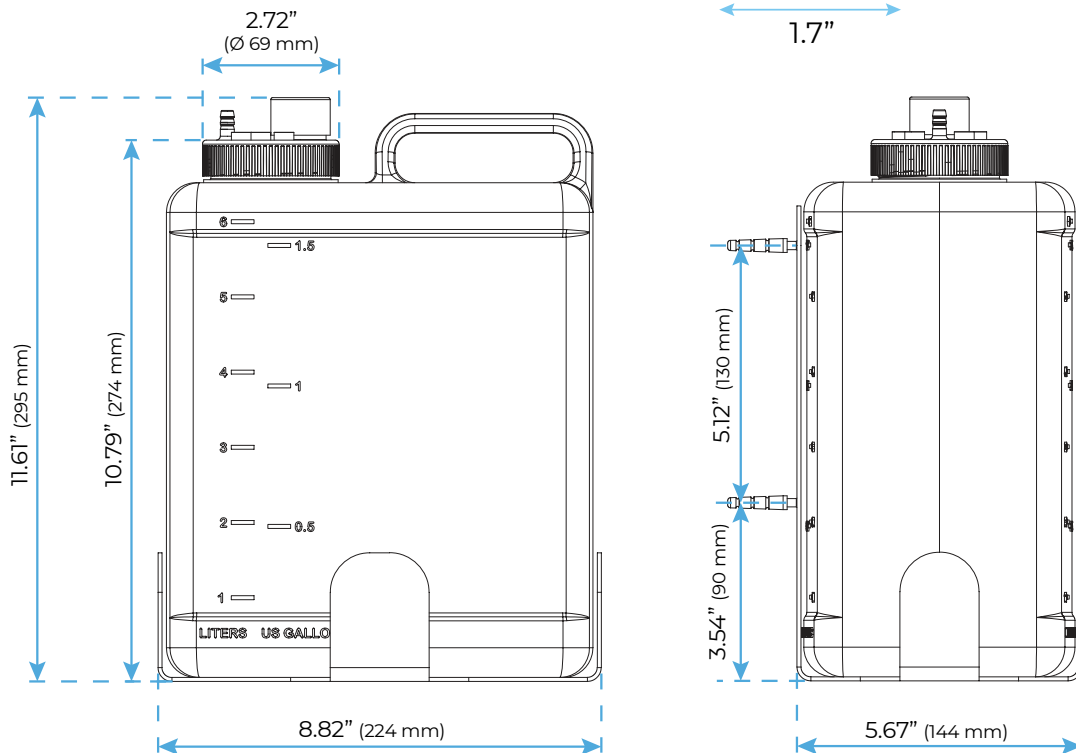
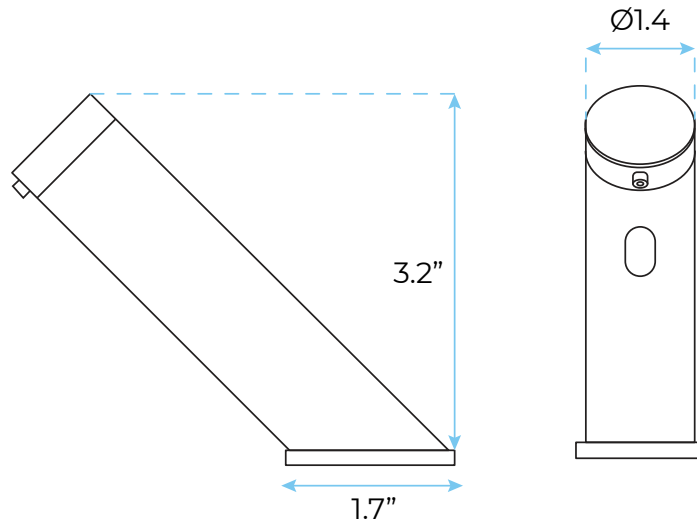

All dimensions and specifications are nominal and may vary. Use actual products for accuracy in critical situations.